

SERVO MOTION CONTROL SOLUTION FOR INJECTION MOLDING

Gantry motion, up to 4 axis

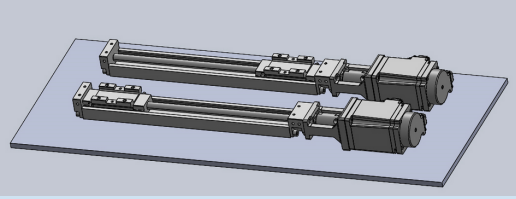

Coordinated Motion

- 1. XYZ gantry
- 2. Caming
- 3. Linear/Circular interpo

S100 controller

- 1. Web server
- 2. Optional wireless
- 3. IEC xxxxx

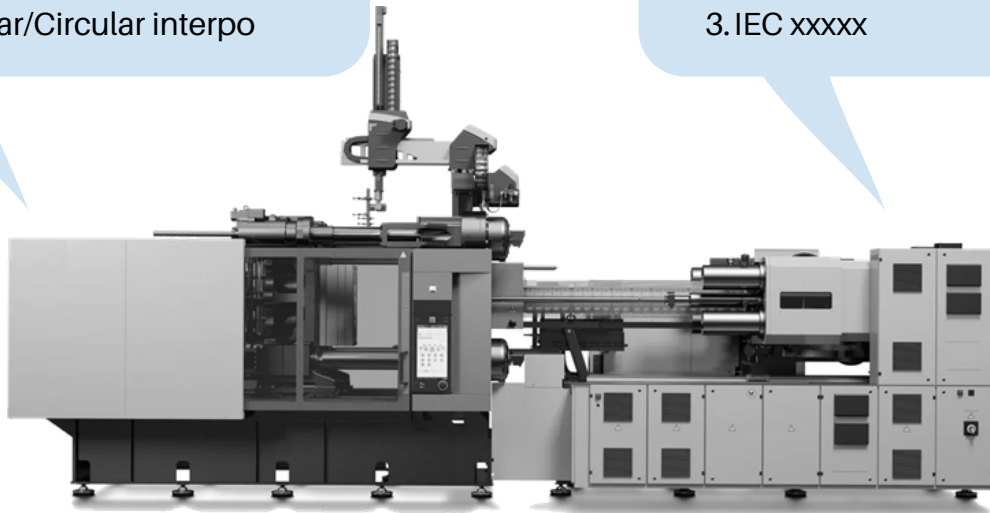

Modular Amplifier



- 1. 400vac
- 2. Large capacity servo
- 3. EtherCAT

Torque control/press, up to 4 axis

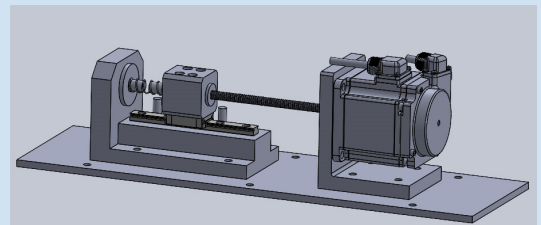

Torque control

- 1. 0.1% control resolution
- 2. On the fly position/torque control switch

