

Development of *SANMOTION R 3E Model* Servo Amplifiers with Built-in Positioning Function

Naohiro Ito Hiroyuki Kosuge Kenichi Fujisawa
 Keisuke Ishizaki Naoki Kubo Hideaki Nishizawa

1. Introduction

In recent years, industrial machinery and automation equipment have been actively introduced in many manufacturing fields with the aim of enhancing productivity and production quality. In light of this, we have developed and released many motion controllers and servo amplifiers that support EtherCAT and other high-speed motion networks. These products are primarily used in machine tools, articulated robots, and other equipment that requires synchronized control of multiple axes.

On the other hand, conveying equipment and indexing applications that perform PTP (point to point) positioning control require systems that allow simple positioning from a PLC using contact signals or universal serial communication. This article will introduce the *SANMOTION R 3E Model* servo amplifiers with a built-in positioning function, and discuss the features and key points of their development.

2. Product Overview

2.1 Appearance and dimensions

The new servo amplifiers are available in two types of interface: a parallel type with I/O contacts and a serial type (RS-485, Modbus RTU) for different interfaces.

Figure 1 shows a parallel type with a 200 VAC input and 150 A amplifier capacity, while Figure 3 shows its dimensions.

Figure 2 shows a serial type with a 200 VAC input and 30 A amplifier capacity, while Figure 4 shows its dimensions.

For all input power and amplifier capacity variations, the dimensions of the new models are the same as those of the *SANMOTION R 3E Model* analog/pulse train interface type and EtherCAT interface type amplifiers, maintaining mounting compatibility.

In addition, the new lineup includes Safety models equipped with functional safety specifications, and models with 400 VAC input.

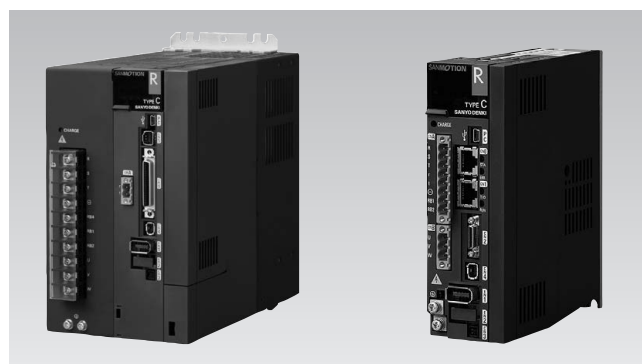

Fig. 1 Appearance of the parallel type (I/O) 200 VAC, 150 A model

Fig. 2 Appearance of the serial type (RS-485 compliant) 200 VAC, 30 A model

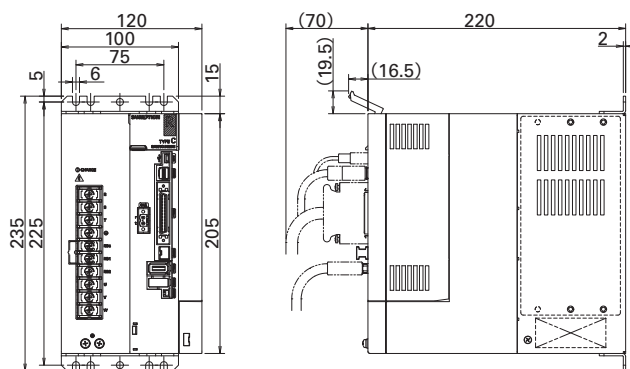

Fig. 3 Dimensions of the parallel type 200 VAC, 150 A model

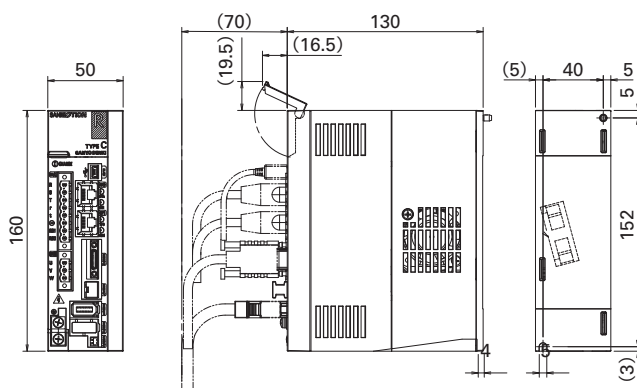

Fig. 4 Dimensions of the serial type 200 VAC, 30 A model

2.2. Basic specifications

1) Servo amplifier specifications

Table 1 shows the basic servo amplifier specifications.

Table 1 Basic specifications

Items		Specifications
Compatible	Input power supply	200 to 240 VAC
		100 to 120 VAC
		380 to 480 VAC
	Compatible motors	SANMOTION R series rotary motors
		SANMOTION DD, DS series linear motors
	Compatible encoders	Standard
Absolute encoder for incremental systems		
Options		Battery-backup absolute encoder
		Wire-saving incremental encoder
		EnDat2.2 encoder (HEIDENHAIN)
Environment	Operation and storage temperature	0 to +55°C, -20 to +65°C
	Operating and storage humidity	Below 90% RH (non-condensing)
	Operating altitude	Below 1,000 m
	Vibration/impact	4.9 m/s ² / 19.6 m/s ²
Safety functions	Amplifier	STO (Safe Torque Off)
	Functional safety module	STO, SS1, SS2, SLS, SOS, SSM, SBC
Function	Mechanical vibration/resonance suppression	<ul style="list-style-type: none"> · FF vibration suppression control (2 levels) · Vibration control for track control · Adaptive notch filter
	Servo tuning	<ul style="list-style-type: none"> · Auto-tuning response 40 levels · Servo tuning support function
	Setup software	<ul style="list-style-type: none"> Start-up, monitoring, diagnosis · Virtual motor operation · Encoder/amplifier temperature monitoring · Power consumption monitoring · Drive recorder · Service life diagnosis (Relay and holding brake) · Encoder communication quality monitoring
Standards	UL/cUL	UL 61800-5-1/C22.2 No274-13
	Low Voltage Directive	EN 61800-5-1
	EMC Directive	EN 61800-3, EN 61326-3-1
	Functional safety	ISO 13849-1: PL=e EN 61508: SIL3, EN 62061: SILCL3
	KC Mark	KN 61000-6-2, KN 61000-6-4

2) Positioning function specifications

Table 2 shows the specifications of the positioning function.

Table 2 Positioning function specifications

Number of controllable axes	1 axis	
Number of points	254 max.	
Command range	-2,147,483,648 to +2,147,483,647	
Command unit	mm, deg, pulse	
Acceleration/deceleration	Linear/S-curve can be switched	
Point data setting	Numerical input with <i>SANMOTION Motor Setup Software</i> or by teaching	
Point number setting	Parallel 8 bit (binary code)	Serial 8 bit (binary code)
Torque limit	0 to 799% (With 100% being the rated value. Peak torque cannot be exceeded)	
Software limit	Available	
Operation modes	Point specification	
	Homing	
	Manual (Jog)	
	Manual (1 step)	
Zone signal	8 zones max.	

2.3 Interface specifications

We have developed two types to interface with host controllers; a parallel type (I/O) and a serial type (RS-485, Modbus RTU). Users can choose the optimal interface for their device's system. Table 3 shows the interface specifications.

Table 3 Interface specifications

Interface		Parallel type	Serial type
		(I/O)	(RS-485 compliant)
Input	General-purpose input	None	7ch
	Dedicated input	20ch	None
	Point specification	8ch	Via communication
Output	General-purpose output	None	2ch
	Dedicated output	17ch	None

1) Parallel type (I/O)

The parallel type allows easy positioning using only contact I/O signals. For servo amplifier output signals, this parallel type supports both sinking and sourcing type controller input signals.

2) Serial type (RS-485, Modbus RTU)

The serial type uses the RS-485 Modbus RTU protocol developed for communication with PLCs and peripheral devices to connect to a variety of controllers. Users can easily check positioning control, parameter settings, and servo amplifier/motor status simply by using the respective coil and register read and write commands. Table 4 shows the communication specifications of the serial type.

Table 4 Serial type communication specifications

Items	Details	Initial value	Remarks
Protocol	Modbus RTU	—	Fixed to binary mode
Interface	RS-485 (1 to N)	—	8 axes max.
Transmission speed (bps)	4800, 9600, 19200, 38400, 57600, 115200	115200	
Start bit	1	1	Fixed
Data length (bit)	8	8	Fixed
Parity	None, even number, odd number	Even number	
Stop bit	1, 2	1	
Electrical specifications	RS-485 compliant (half-duplex communication)	—	Fixed
Connector	RJ-45	—	

3. Features

3.1 Positioning control with a high degree of freedom

The features of the new models' positioning control function are summarized as follows.

1) Basic functions

A maximum of 254 points of positioning can be set according to preset point data by simply specifying point numbers from a host controller. Profile data such as speed and S curve acceleration/deceleration, servo gain switchover selection, and current limit values can be set for each point to achieve fine-tuned control tailored to machine conditions.

2) Continuous operation

In addition to positioning to single points, continuous operation between points is also possible. There are two forms of continuous operation, "punctuated speed change operation" in which the motor stops and changes speed at each point (Figure 5), and "continuous speed change operation" in which the motor changes speed while passing through points (Figure 6). Users can select the operation type suited to their application.

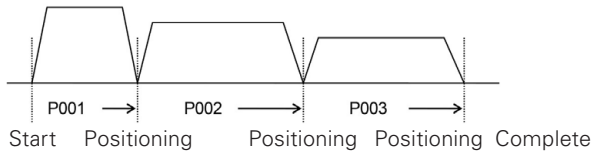

Fig. 5 Punctuated speed change operation

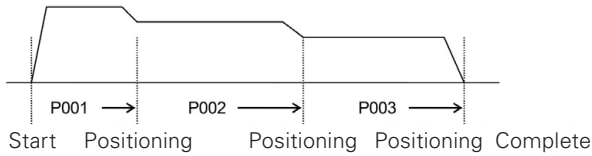

Fig. 6 Continuous speed change operation

3) Shortcut control

Positioning coordinate ranges can be set to arbitrary values to suit machine conditions in applications in which motors continue rotating without limit in a certain direction, such as machine tool indexing equipment. This makes it possible to perform positioning with coordinates matching the machine’s position even when the motor is constantly rotating. Moreover, as shown in Figure 7, the shortcut control function automatically detects the shortest path to the target destination, thereby improving cycle time.

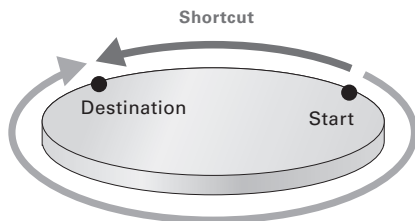

Fig. 7 Illustration of shortcut control

4) Simple program operation

As Figure 8 shows, the new models have a simple program function to perform an unconditional jump to a specified point after moving to a certain point, or perform the same operation a specified number of times. This reduces the burden on the host controller.

These abundant functions can help easily build flexible positioning control systems with a high degree of freedom without using special-purpose positioning controllers, reducing wiring and saving space.

✓ Unconditional jump, jumps to any point.

POINT	Displacement	Loop mode	JP	Repeat count
0	8192	1	253	0

Jumps to point 253 after performing point 0.

✓ Loops to specified point for specified number of times.

POINT	Displacement	Loop mode	JP	Repeat count
3	0	0	0	0
4	1000	0	0	0
5	-1000	3	4	3
6	8192	3	4	3

3 times repeat

Fig. 8 Simple program operation

3.2 Safety functions

The new lineup also includes Safety models that have a variety of functional safety features such as “Safe Torque Off (STO),” “Safe Stop (SS1, SS2),” and “Safely-Limited Speed (SLS).” This makes it possible to safely stop and rotate the motor, and easily build safety systems for equipment. Also, to remove motor torque in an emergency with conventional servo amplifiers, it has been necessary to isolate the amplifier’s power from the motor with a magnet switch. Now, thanks to the STO function, there is no need to isolate power, so equipment restart time can be shortened.

3.3 Startup support function

Point data necessary for positioning control can be set from a computer with the *SANMOTION MOTOR SETUP SOFTWARE* (hereinafter “setup software”). This setup software has an editing function for straightforward point data registration, as well as support functions such as point movement and trial operation to easily check motor and equipment movement. These functions simplify equipment startup.

Figure 9 shows the screen for setting and editing point data. When the row of the point to be set is clicked, an easy to understand point data editing screen displaying those items required for setting appears, and users can easily set point data.

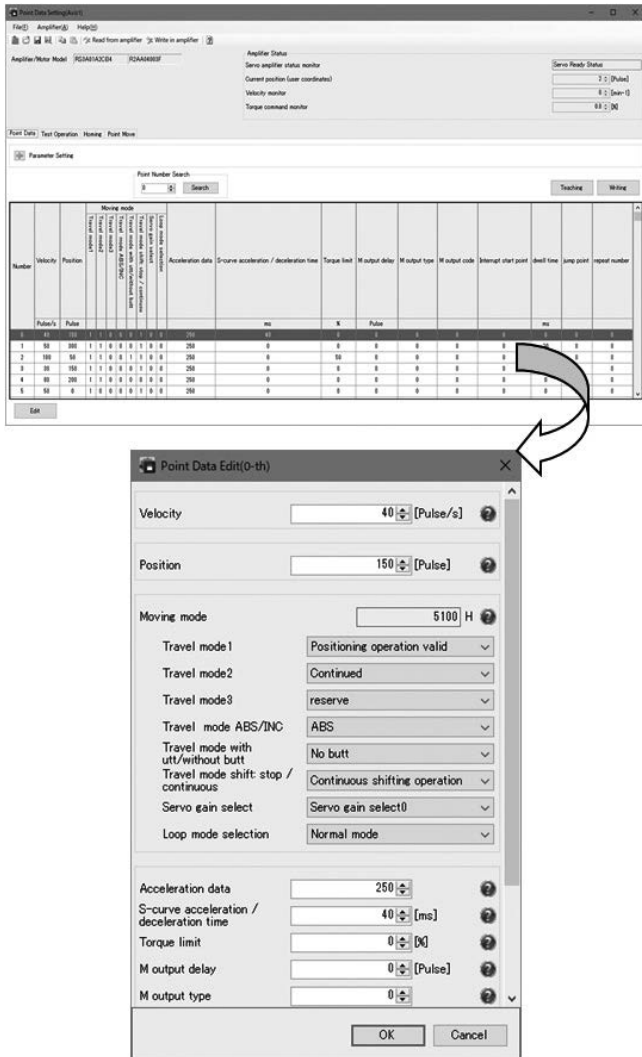

Fig. 9 Point data setting/editing screen

4. Key Points of Development

These new models maintain compatibility with the current models' positioning functions, and expand on the existing lineup with the addition of multiple versions, such as 400 VAC models, high-capacity models, and Safety models. In this section we will introduce some of the key points of development, such as our efforts to simplify replacement of the current models, and our efforts to simultaneously add a wide variety of products to our lineup.

4.1 Easy replacement

To simplify replacement of the current models with the new models, we focused on the following measures.

(1) Compatibility

By maintaining compatibility with the current models for each positioning function, there is no longer a need to reprogram the host controller. Moreover, compatibility is maintained with point data files prepared for current models

so they can be used on the new models without changing or recreating point data.

(2) Parameter conversion tool

While servo gain and other parameter files are not compatible, we have prepared a tool that automatically converts parameter files prepared for the current models so they can be used on the new models.

4.2 Standardized design

To support the rich *SANMOTION R 3E Model* lineup, we focused on standardizing design, thereby shortening the development period.

(1) Standardized output circuit

The current models have different output circuits for different controller input specifications (sinking or sourcing). The new models, however, have standardized output circuits that support both.

(2) Standardized components

As far as possible, components have been standardized with those of analog/pulse train and EtherCAT models (such as resin cases and die castings) to improve structural design efficiency.

(3) Integrated software

We have shortened the software development period by innovating software configuration and module design, and integrating the software for parallel and serial types.

(4) Reduced number of product models

By standardizing output circuits and making Safe Torque Off (STO) a standard feature, the total number of models have been reduced to one-quarter of that of the analog/pulse train interface models. This helps reduce our customers' management labor.

5. Conclusion

This article has provided an overview and discussed the features and key development points of the new lineup of *SANMOTION R 3E Model AC* servo amplifiers with a built-in positioning function.

The new models feature:

- (1) Rich positioning functions such as a maximum of 254 positioning points, continuous operation, and simple program operation.
- (2) Available in two interface types, a parallel type (I/O) and serial type (RS-485, Modbus RTU). Users can select the optimal interface for their controller specifications.
- (3) We also have a lineup of Safety models, making it easier to build safety systems in equipment and contributing to machine safety.
- (4) Enhanced setup software functions such as functions for

straightforward registration/editing of point data and easy check of motor movement, which are more user-friendly than the current models.

- (5) Compatibility with the positioning functions and point data files used in our current models, making model replacement easy.
- (6) Standardized output circuit (sinking/sourcing types), standard Safe Torque Off (STO) feature, and reduced number of product models to reduce customers' management labor.

We believe these servo amplifiers will help significantly improve cost performance by contributing to downsizing and wire-saving in devices as they enable easy system construction in PTP positioning applications without the need for a special-purpose positioning controller. Moving forward, we will continue developing and proposing new products embedded with IoT functions to help customers improve the quality of their operations.

Author

Naohiro Ito

Servo Systems Div., Design Dept. 2

Works on the development and design of servo amplifiers.

Hiroyuki Kosuge

Servo Systems Div., Design Dept. 2

Works on the development and design of servo amplifiers.

Kenichi Fujisawa

Servo Systems Div., Design Dept. 2

Works on the development and design of servo amplifiers.

Keisuke Ishizaki

Servo Systems Div., Design Dept. 2

Works on the development and design of servo amplifiers.

Naoki Kubo

Servo Systems Div., Design Dept. 2

Works on the development and design of servo amplifiers.

Hideaki Nishizawa

Servo Systems Div., Design Dept. 2

Works on the development and design of servo amplifiers.